

# MANUAL

HALO NANOCAM

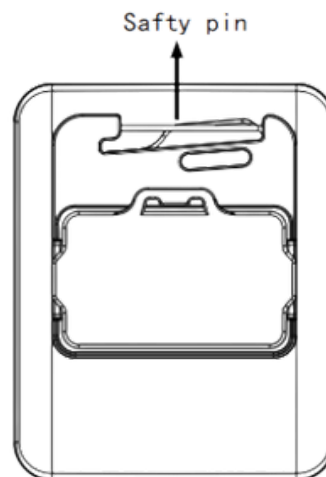

## PRODUCT INFORMATION:

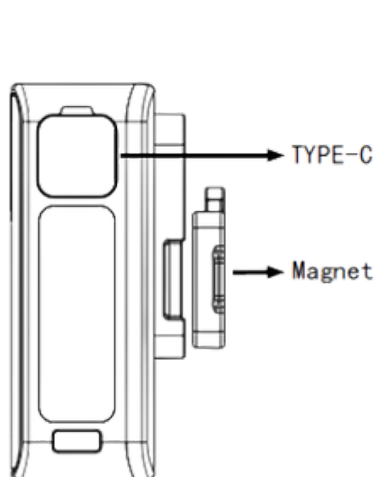
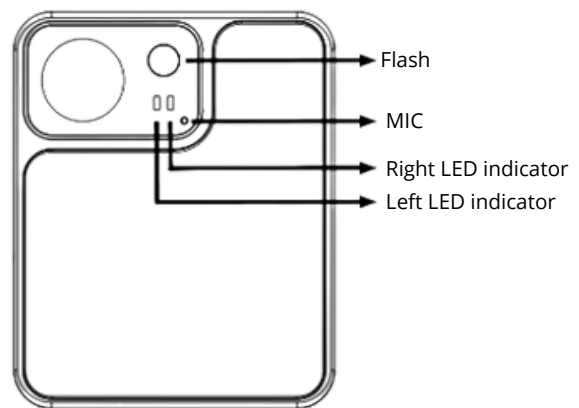
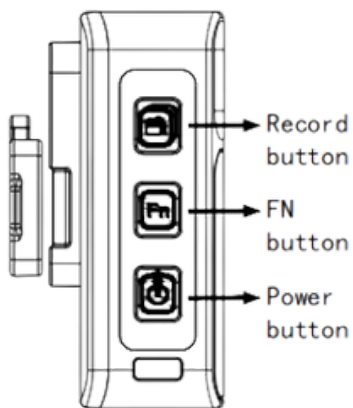
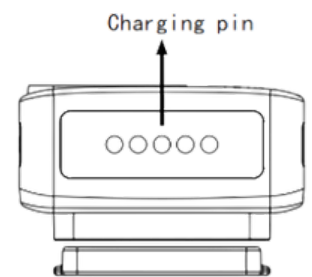
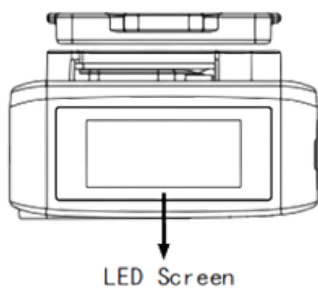

# MANUAL

## HALO NANOCAM

### BUTTON INFORMATION:

Button	Short press	Double tap
Record	N/A	-Recording Start/Stop - Panic Alert - Livestream Server Active
FN	N/A	N/A
Power	Brighten screen	Torch ON/OFF



### LED INFORMATION:









LED Indicator	Colour	Description
Left LED	Green	Flashing Standby
	Red	Flashing: Recording
Right LED	Blue	ON: Charging
	Green	ON: Charging completed



# MANUAL

## HALO NANOCAM

### SCREEN INFORMATION:

WIFI connected	
WIFI disconnected	
Camera is live streaming	
Battery level	
Recording resolution (1080P means the resolution is 1920x1080)	
Remain storage and Total storage space	
Ethernet connected - Live connection	
Number of files uploading - E.g file number 6 out of 10 is about to upload	
File upload progress - E.g. file is 59% uploaded into Vault	

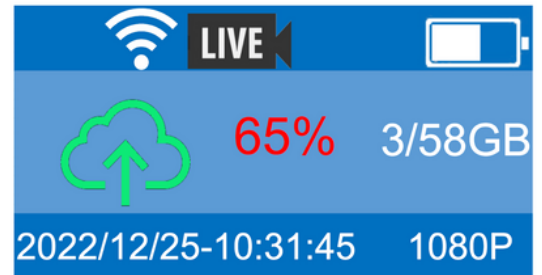

### CHARGING:

1. Plug in the type-C USB provided into the back of the charging dock.
2. Once you have turned on the plug, the right LED should turn to constant blue. This means the camera is charging.
3. To remove the camera from the dock - Do not do so in an upward motion. The camera must be tilted forward and then lifted from the dock.

# MANUAL

## HALO NANOCAM

### FCC WARNING

This device complies with part 15 of the FCC Rules. Operation is subject to the following two conditions: (1) this device may not cause harmful interference, and (2) this device must accept any interference received, including interference that may cause undesired operation.

Any changes or modifications not expressly approved by the party responsible for compliance could void the user's authority to operate the equipment.

NOTE: This equipment has been tested and found to comply with the limits for a Class B digital device, pursuant to Part 15 of the FCC Rules. These limits are designed to provide reasonable protection against harmful interference in a residential installation. This equipment generates, uses and can radiate radio frequency energy and, if not installed and used in accordance with the instructions, may cause harmful interference to radio communications. However, there is no guarantee that interference will not occur in a particular installation.

If this equipment does cause harmful interference to radio or television reception, which can be determined by turning the equipment off and on, the user is encouraged to try to correct the interference by one or more of the following measures:

- Reorient or relocate the receiving antenna.
- Increase the separation between the equipment and receiver.
- Connect the equipment into an outlet on a circuit different from that to which the receiver is connected.
- Consult the dealer or an experienced radio/TV technician for help. The device has been evaluated to meet general RF exposure requirement. The device can be used in portable exposure condition without restriction.